

## Stratos T2 POE Series

### TFOCA POE Media Converters

#### Ethernet Connectivity in Rugged Environments

The Cinch Stratos T2 series media converter is a 2-channel optical transceiver and media converter. Each channel interfaces with up to 1000MBPS Ethernet electrical signals and converts to/from up to 1000MBPS optical signals. The optical interface uses a TFOCA-II 4-CH connector and supports a variety of optical wavelengths & fiber modes. The modular electrical interface uses POE RJ45 mag-jacks.



#### Features

- Support up to a 2GBPS ethernet link (2 channels at 1GBPS each) over fiber between linked devices.
- Rugged MIL Circular Connector or RJ45 POE for electrical interface.
- All units are 100% tested at both temperature extremes prior to shipment.
- MIL-STD-810 qualified for temperature, thermal shock, vibration, mechanical shock, humidity, and altitude.
- FCC Class A compliant with internal & external EMI sealing.
- Built and tested in the USA.
- Internal construction includes use of tin-lead Solder & Conformal Coating.
- Rugged PTFE anodized finish & all stainless-steel hardware.



#### Applications

Oil & Gas  
Fire & Rescue  
Security  
Shipboard  
Tactical Communications  
Military Communications

## Part Number Ordering Options

Part Number	Ethernet Rates	Optical Rate	Optical Signal	Distance	Link Fault	Cross Channel
T2F-RJ002-POE	10/100BT	FE (125Mbps)	1310 nm Multimode	2 km		
T2F-RJ002-POE-01	10/100BT	FE (125Mbps)	1310 nm Multimode	2 km	X	
T2F-RJ002-POE-03	10/100BT	FE (125Mbps)	1310 nm Multimode	2 km	X	X
T2K-RJ002-POE	10/100/1000BT	GE (1.25Gbps)	850 nm Multimode	1 km		
T2K-RJ002-POE-01	10/100/1000BT	GE (1.25Gbps)	850 nm Multimode	1 km	X	
T2K-RJ002-POE-03	10/100/1000BT	GE (1.25Gbps)	850 nm Multimode	1 km	X	X
T2K-RJ202-POE	10/100/1000BT	GE (1.25Gbps)	1310 nm Multimode	1 km		
T2K-RJ202-POE-01	10/100/1000BT	GE (1.25Gbps)	1310 nm Multimode	1 km	X	
T2K-RJ202-POE-03	10/100/1000BT	GE (1.25Gbps)	1310 nm Multimode	1 km	X	X
T2K-RJ602-POE	10/100/1000BT	GE (1.25Gbps)	1310 nm Singlemode	10 km		
T2K-RJ602-POE-01	10/100/1000BT	GE (1.25Gbps)	1310 nm Singlemode	10 km	X	
T2K-RJ602-POE-03	10/100/1000BT	GE (1.25Gbps)	1310 nm Singlemode	10 km	X	X

### Notes:

- 1) Ethernet rates are auto-negotiated on the copper port side to 10BT, 100BT, or (in the case of the GigE converter) 1000BT. The optical link rate is always fixed and does not change regardless if the copper side is auto-negotiated down to a lower rate. The Near End and Far End Optical Converters must match the optical rate, wavelength, and fiber type (singlemode or multimode) for proper operation.
- 2) Link distances may be improved by using higher bandwidth rated fiber. For example, using OM4 rated multimode fiber could extend GE optical link distance to 2 km.

## Absolute Maximum Ratings

Parameter	Symbol	Min	Typical	Max	Unit
Storage Temperature	Ts	-55		+100	C
Supply Voltage - DTL	Vcc	0		+35	V
Supply Voltage - PoE, Per IEEE 802.3AF	Vcc	0		+60	V

## Recommended Operating Conditions

Parameter	Symbol	Min	Typical	Max	Unit
Case Operating Temperature	Ts	-40		+71	C
Supply Voltage - POE	Vs	+2.8	+48	+57	V
Power Draw	Ps		5.0	6.0	W

## Block Diagram, T2 Series POE Media Converter

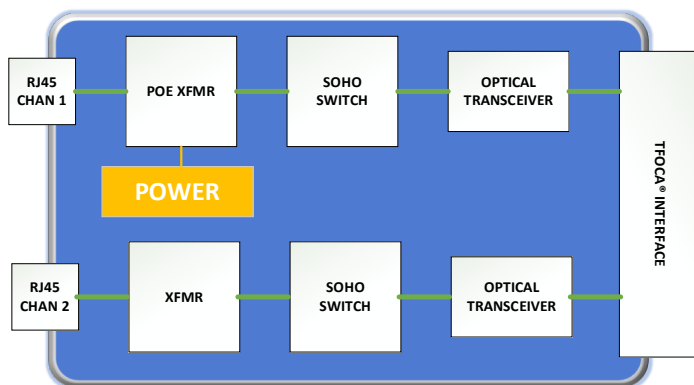

## TFOCA Cross Channel Option (-03 versions)

Cross Option	Electrical RJ45	Optical TFOCA
No (BLANK, -01)	Chan 1	P2/S2
Yes (-03)	Chan 1	P1/S1
	Chan 2	P2/S2

**Note** — Historic versions of the Stratos Media Converters use TFOCA P2/S2 pin and socket for Channel 1. This nomenclature has been preserved in order to provide backwards compatibility to those older systems.

## Block Diagram Description

The electrical signals are transformer coupled into a Physical Layer Device (PHY), buffered, and then regenerated into up to an optical data stream. The optical data stream is then routed to an internal optical transceiver to create the optical signal. The optical signal is routed to the TFOCA-II compatible connector interface for direct connection to a tactical optical cable.

The media conversion process is compliant to the IEEE 802.3 specifications for Fast Ethernet 100BT and 100BFX, as well as the IEEE 802.3Z specifications for Gigabit Ethernet 100/1000BT and 1000BLX. The Ethernet connection supports auto-negotiation for 10/100/1000BT interfaces. In the case of auto-negotiation to a lower ethernet rate on the copper link, the optical link is always at the fixed rate of either 125Mbps (T2F series) or 1.25Gbps (T2K series). The Ethernet connection also supports auto-cross to automatically support both crossed and un-crossed ethernet cables.

POE Power is supplied to the entire converter (to both channels) through RJ45 Channel 1 only. There is no internal POE power circuit for the RJ45 channel 2.

## Optical Performance, T2F Series (Fast Ethernet)

Applicable part numbers: T2F-RJ002-POE, T2F-RJ002-POE-01, T2F-RJ002-POE-03

Parameter	Symbol	Min	Typical	Max	Unit
Transmit Output Power	$P_o$	-12.0	-	-3.0	dBm
Transmit Output Center Wavelength	$\lambda_{OUT}$	1263	1310	1360	nm
Transmit Output Spectral Width	$\Delta\lambda_{RMS}$	-	-	4	nm
Transmit Extinction Ratio	ER	8	10	-	dB
Transmit Rise/Fall Time (10-90%)	$t_R$	-	-	3000	ps
Receive Sensitivity	$P_i$	-32.0	-	-3.0	dBm
Receive Wavelength	$\lambda_{IN}$	1270	-	1355	nm
Fiber Core Diameter	$\phi_{CORE}$	-	63	-	um

## Optical Performance, T2K Series (Gigabit Ethernet), 850 nm Multimode

Applicable part numbers: T2K-RJ002-POE, T2K-RJ002-POE-01, T2K-RJ002-POE-03

Parameter	Symbol	Min	Typical	Max	Unit
Transmit Output Power	$P_o$	-10.0	-	-4.0	dBm
Transmit Output Center Wavelength	$\lambda_{OUT}$	830	850	860	nm
Transmit Output Spectral Width	$\Delta\lambda_{RMS}$	-	-	0.85	nm
Transmit Extinction Ratio	ER	8	10	-	dB
Transmit Rise/Fall Time (10-90%)	$t_R$	-	-	260	ps
Receive Sensitivity	$P_i$	-20.0	-	-3.0	dBm
Receive Wavelength	$\lambda_{IN}$	800	-	860	nm
Fiber Core Diameter	$\phi_{CORE}$	-	63	-	um

## Optical Performance, T2K Series (Gigabit Ethernet), 1310 nm Multimode

Applicable part numbers: T2K-RJ202-POE, T2K-RJ202-POE-01, T2K-RJ202-POE-03

Parameter	Symbol	Min	Typical	Max	Unit
Transmit Output Power	$P_o$	-10.0	-	-4.0	dBm
Transmit Output Center Wavelength	$\lambda_{OUT}$	1285	1310	1343	nm
Transmit Output Spectral Width	$\Delta\lambda_{RMS}$	-	-	4	nm
Transmit Extinction Ratio	ER	8	10	-	dB
Transmit Rise/Fall Time (10-90%)	$t_R$	-	-	260	ps
Receive Sensitivity	$P_i$	-20.0	-	-3.0	dBm
Receive Wavelength	$\lambda_{IN}$	1270	-	1355	nm
Fiber Core Diameter	$\phi_{CORE}$	-	63	-	um

## Optical Performance, T2K Series (Gigabit Ethernet), 1310 nm Singlemode

Applicable part numbers: T2K-RJ602-POE, T2K-RJ602-POE-01, T2K-RJ602-POE-03

Parameter	Symbol	Min	Typical	Max	Unit
Transmit Output Power	$P_o$	-8		0	dBm
Transmit Output Center Wavelength	$\lambda_{OUT}$	1285	1310	1343	nm
Transmit Output Spectral Width	$\Delta\lambda_{FIMS}$			4	nm
Transmit Extinction Ratio	ER	8	10		dB
Transmit Rise/Fall Time (10-90%)	$t_R$			260	ps
Receive Sensitivity	$P_i$	-20		0	dBm
Receive Wavelength	$\lambda_{IN}$	1270		1355	nm
Fiber Core Diameter	$\phi_{CORE}$		9		um

### Optical Pinout and Cross Options

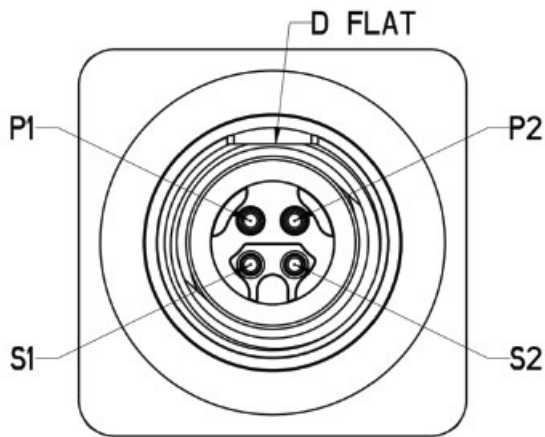

Pin/Socket	Cross = NO (blank or -01)	Cross = YES (-03 suffix)
P1	RX2—Channel 2 optical input	RX1—Channel 1 optical input
S1	TX2—Channel 2 optical output	TX1—Channel 1 optical output
P2	RX1—Channel 1 optical input	RX2—Channel 2 optical input
S2	TX1—Channel 1 optical output	TX2—Channel 2 optical output

**Cross option = YES** applies to part numbers that end in “-03” only. For example, T2F-RJ002-POE-03 or T2K-RJ002-POE-03.

### Link Control Options

Link control options (-01 or -03 suffix) will force the copper Ethernet link to a disconnect state when the optical link goes down. When the optical link is re-established, the Ethernet is reconnected. In this fashion, the host system is able to detect no connectivity unless both the copper and optical link are up.

Media Converters without link control (blank suffix) leave the copper Ethernet link always connected, regardless of the state of the optical link.

## Electrical Connector and Signal Definitions

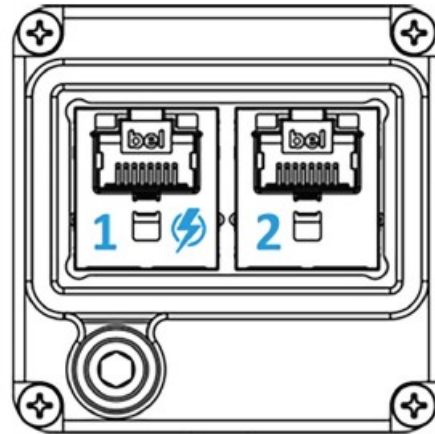

T568B / 802.3AF Mode B  
PoE Power Input on Channel 1 only

### Channel 1

Pin	Signal 100/100 Mbps	Signal 1000 Mbps	Power (PoE)	Color	Color Description
1	RX+	TxRx A+	-	//////	White with orange stripe
2	RX-	TxRx A-	-	//////	Solid orange, orange with white stripe
3	TX+	TxRx B+	-	//////	White with green stripe
4	-	TxRx C+	DC+	//////	Solid blue, blue with white stripe
5	-	TxRx C-	DC+	//////	White with blue stripe
6	TX-	TxRx B-	-	//////	Solid green, green with white stripe
7	-	TxRx D+	DC-	//////	White with brown stripe
8	-	TxRx D-	DC-	//////	Solid brown, brown with white stripe

### Channel 2

Pin	Signal 100/100 Mbps	Signal 1000 Mbps	Power (PoE)	Color	Color Description
1	RX+	TxRx A+	-	//////	White with orange stripe
2	RX-	TxRx A-	-	//////	Solid orange, orange with white stripe
3	TX+	TxRx B+	-	//////	White with green stripe
4	-	TxRx C+	DC+	//////	Solid blue, blue with white stripe
5	-	TxRx C-	DC+	//////	White with blue stripe
6	TX-	TxRx B-	-	//////	Solid green, green with white stripe
7	-	TxRx D+	DC-	//////	White with brown stripe
8	-	TxRx D-	DC-	//////	Solid brown, brown with white stripe

Notes:

POE Power is active only on RJ45 Channel 1, and powers both channels of the Media Converter.

## Mechanical Properties

### Plating Specification

**EMI conductive seal area**  
 Chem film per MIL-DTL-5541 Type 1, Class 111  
 Color: Clear

**All other areas**  
 Hard Coat Anodize IAW MIL-A-8625  
 Type III, Class 2, Polytetrafluoroethylene (PTFE) Impregnated,  
 0.0012in-.0018in THK  
 Color: Black

### External O-Ring

**Standard EMI O-Ring**  
 Silicone Elastomer  
 Binder with silver aluminum conductive  
 Filler IAW MIL-DTL-83528G  
 Color: Light beige or blue  
 (Color depending on supplier)  
 Other external O-rings (non-conductive / non-EMI available by request)



### Label

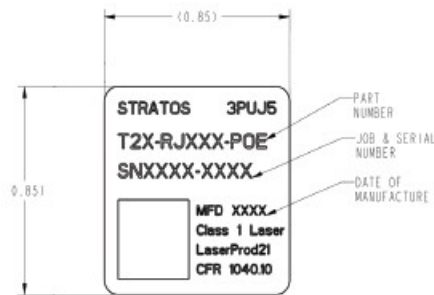

### Bulkhead Cutout Dimension

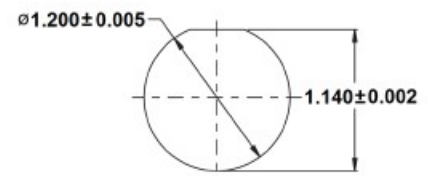

\*All dimensions in inches

### Torque Specifications

Item	Torque (in - lbs)	Recommended Tool	Description
Jam nut, optical lanyard	22 ± 2	1-3/8in	Wrench / socket wrench
Screw, grounding lug	22 ± 2	5/32in	Hex wrench

# T2 POE Series Media Converters



## Mechanical Dimensions (inches)

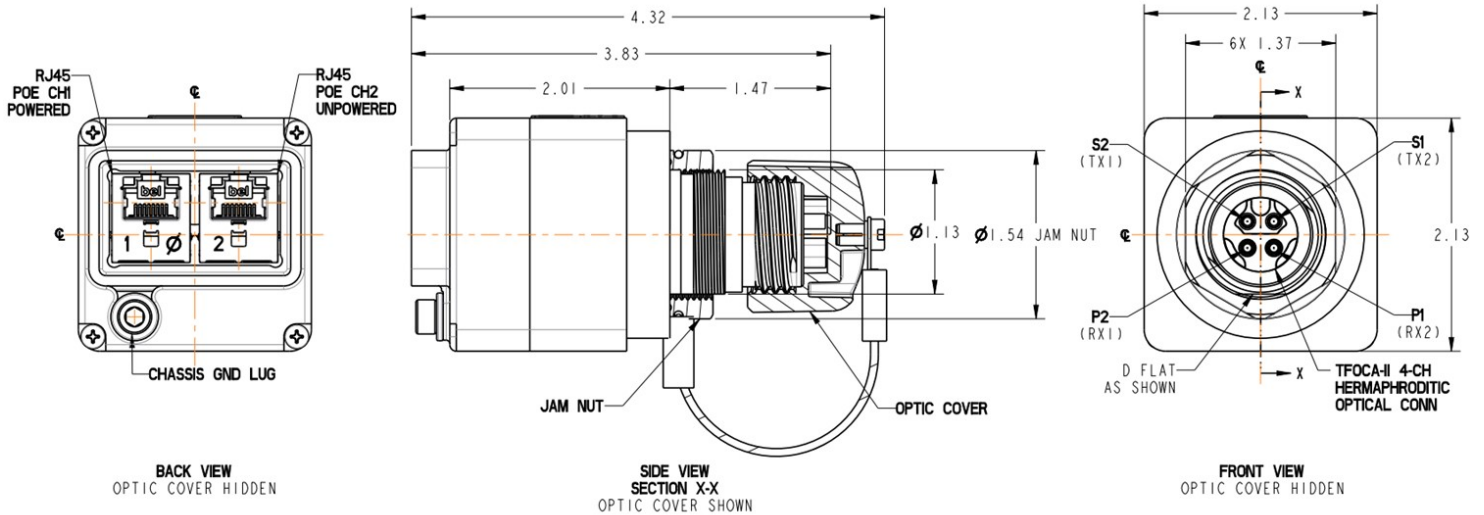

## TFOCA Connector Key Options



Default (Standard Key)



Key Option K2



Key Option K3



Key Option K4 (Universal)

The T2 Series Media Converters are normally offered with the **Default (Standard) Key** on the TFOCA optical connector. Other Key options are available, consult the factory for alternate Key part numbers.



## Environmental Compliance

Category	Standard	Conditions
Operating Temperature	MIL-STD-810, Method 501 & 502	-40°C to +71°C
Thermal Shock	MIL-STD-810, Method 503	-40°C to +71°C
High Temp Operating Life	MIL-STD-202G, Section 108A	1000 hours at +71°C
Vibration	MIL-STD-810, Method 514.6	16.9 GRMS, 3 axes, 1 hr per axis
Mechanical Shock	MIL-STD-810, Method 516.6	20G peak, 18ms
Humidity	MIL-STD-810, Method 507.5	85% RH, -32°C to +27°C
Altitude	MIL-STD-810, Method 500	40,000ft transport
MTBF	MIL-HDBK-217FN2	100,000 hours, 30°C GB environment

## Regulatory Compliance

Requirement	Feature	Condition	Notes
MIL-STD-883-3015.7	ESD	Class II	2200V
IEC-801-2	ESD	Human body model	25KV
IEC-801-3	EMI	Immunity	10V/M
FCC	EMI	Class A	>20dB
IEC-825 ISSUE 1993-11	Eye safety	Class 1	
FDA CDRH 21-CFR 1040	Eye safety	Class 1	