

PART NUMBER	ITEM ① BODY	ITEM ② CONTACT	ITEM ③ INSULATOR	PACKAGING
125-0701-271	BRASS GOLD PL .00003 MIN OVER NICKEL PL .00005 MIN OVER COPPER	BERYLLIUM COPPER GOLD PL .00005 MIN OVER NICKEL PL .00005 MIN OVER COPPER	TEFLON	TAPE AND REEL 1000 PCS PER FIG 1

REV	ECO	DATE
1	INITIAL RELEASE	11NOV2022

NOTES:

1. ELECTRICAL SPECIFICATIONS:

- 1.1 IMPEDANCE: 50 OHMS
- 1.2 FREQUENCY RANGE: 0-6 GHz
- 1.3 VSWR: 1.5 MAX
- 1.4 WORKING VOLTAGE: 325 VRMS MAX AT SEA LEVEL
- 1.5 DIELECTRIC WITHSTANDING VOLTAGE: 325 VRMS MIN AT SEA LEVEL
- 1.6 INSULATION RESISTANCE: 5000 MEGOHM MIN
- 1.7 CONTACT RESISTANCE:
 - 1.7.1 CENTER CONTACT - INITIAL 6.0 MILLIOHM MAX, AFTER ENVIRONMENTAL NOT APPLICABLE
 - 1.7.2 OUTER CONDUCTOR - INITIAL 2.0 MILLIOHM MAX, AFTER ENVIRONMENTAL NOT APPLICABLE

2. MECHANICAL SPECIFICATIONS:

- 2.1 ENGAGEMENT FORCE: 4.5 LBS TYPICAL
- 2.2 DISENGAGEMENT FORCE: 6.5 LBS TYPICAL
- 2.3 DURABILITY: 100 CYCLES MIN

3. ENVIRONMENTAL:

- 3.1 THERMAL SHOCK: MIL-STD-202, METHOD 107, CONDITION B
- 3.2 OPERATING TEMPERATURE: -65°C TO 165°C
- 3.3 CORROSION: MIL-STD-202, METHOD 101
- 3.4 MECHANICAL SHOCK: MIL-STD-202, METHOD 213, CONDITION I
- 3.5 VIBRATION: MIL-STD-202, METHOD 204
- 3.6 MOISTURE RESISTANCE: MIL-STD-202, METHOD 106, EXCEPT STEP 7B

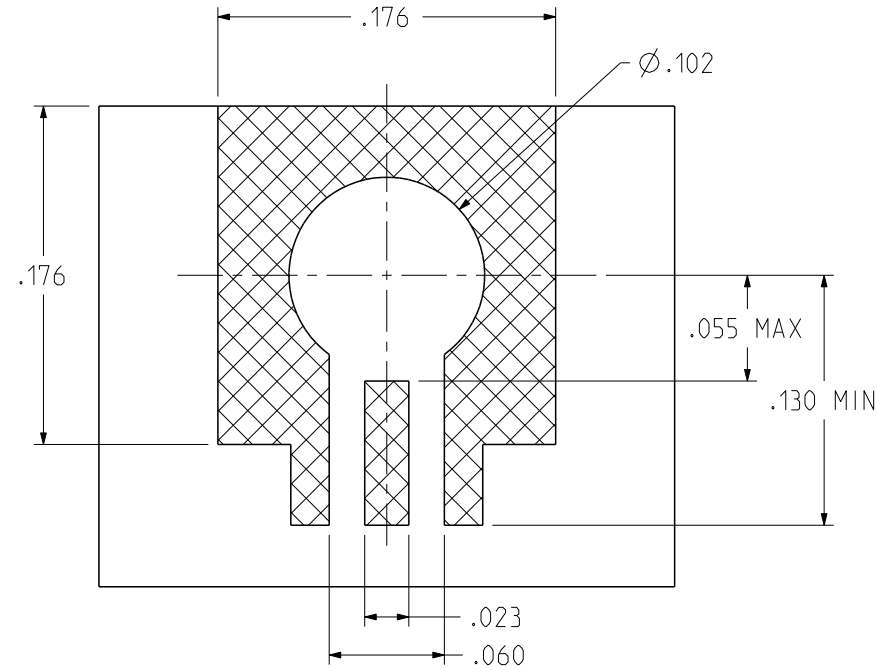

RECOMMENDED PCB LAYOUT

NOTE: THIS PATTERN IS FOR REFERENCE ONLY. PATTERN MAY VARY DEPENDING ON ASSEMBLY PROCESS, BOARD TYPE, OR SPECIFIC ELECTRICAL OR MECHANICAL REQUIREMENTS.

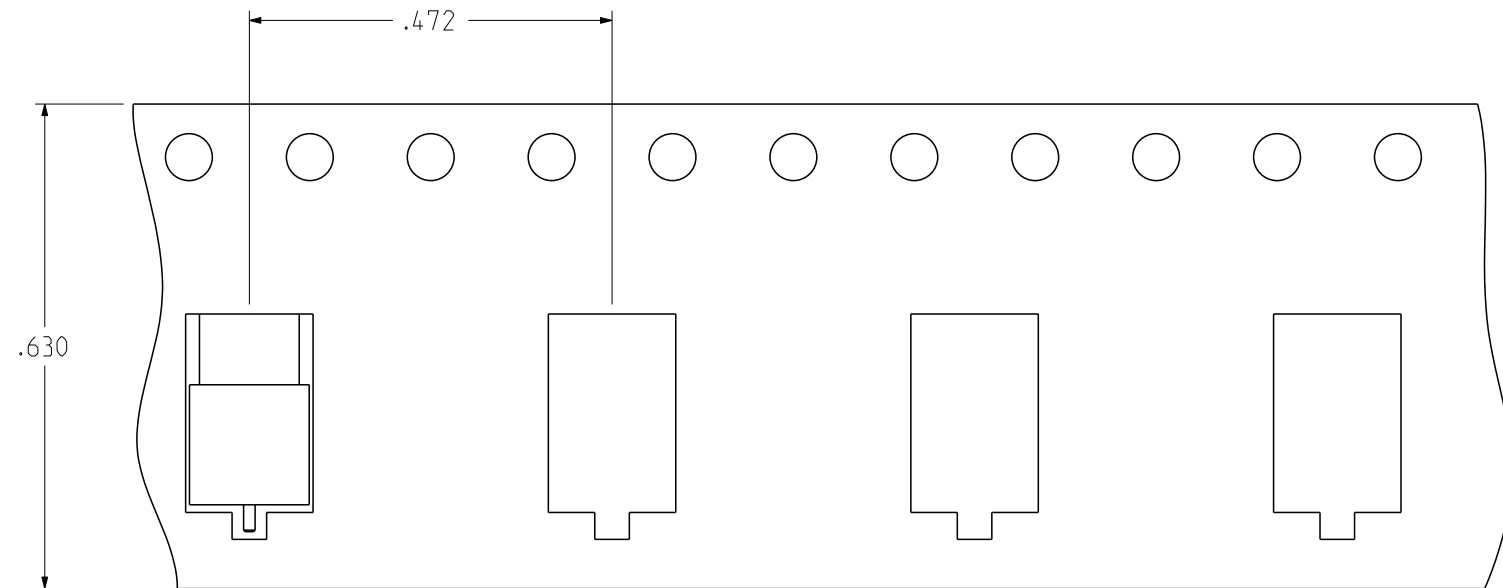
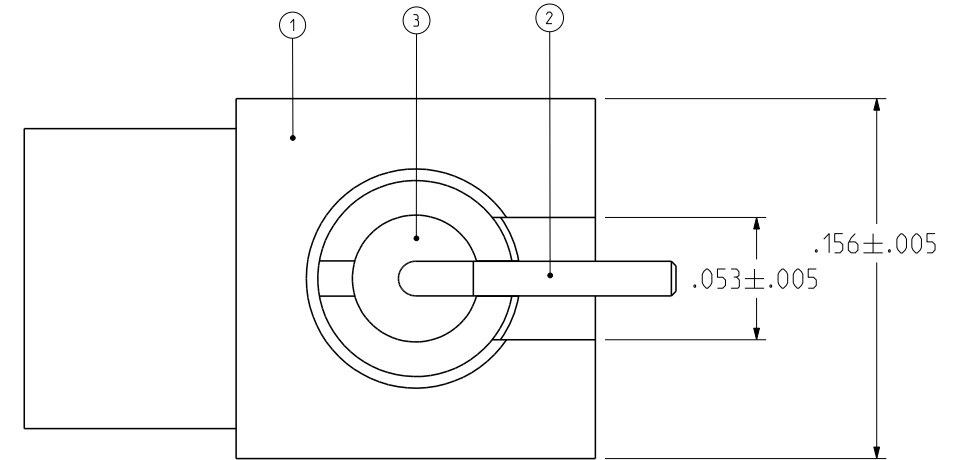
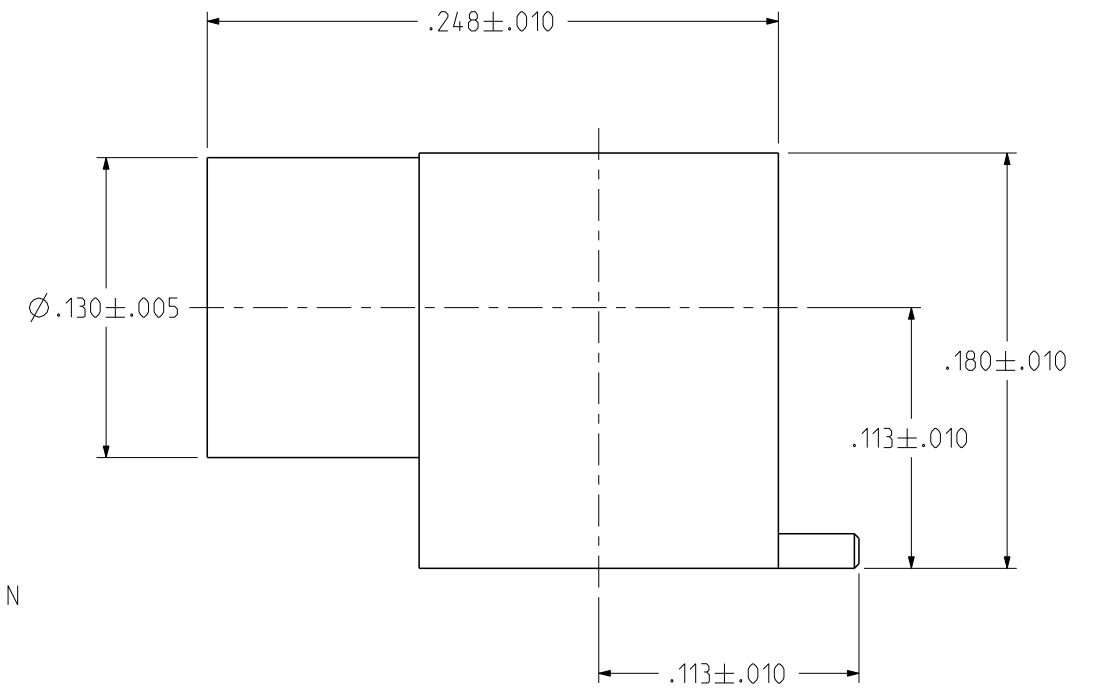

FIG 1

<p>This PROPRIETARY Document is property of Cinch Connectivity Solutions. It is confidential in nature, non-transferable, and issued with the clear understanding that it is not traced or copied without permission and is returnable upon demand.</p> <p>INTERPRET DRAWING IN ACCORDANCE WITH ASME Y14.5-2018.</p>	Model No: 125-0701-271/280	Title: JOHNSON SMPM MALE FULL DETENT RIGHT ANGLE PCB SURFACE MOUNT		
	RoHS <input checked="" type="checkbox"/> (EU)/2015/863 COMPLIANT	Cage Code	Drawing No. 125-0701-271/280	REV. 1
	UNLESS OTHERWISE SPECIFIED UNITS: INCH .XX ± .01 .XXX ± .003 .XXXX ± .0010 ANGLE ± 2°	3RD ANGLE PROJECTION 	Drawn by: TOMMY REN	Workmanship Std: Sheet NONE
	Date: 11/11/2022	Size B	DO NOT SCALE DRAWING	1 OF 1