

DRAWING REVISIONS			
REV	DOCUMENT	APP	DATE
A	DO 05-1162		

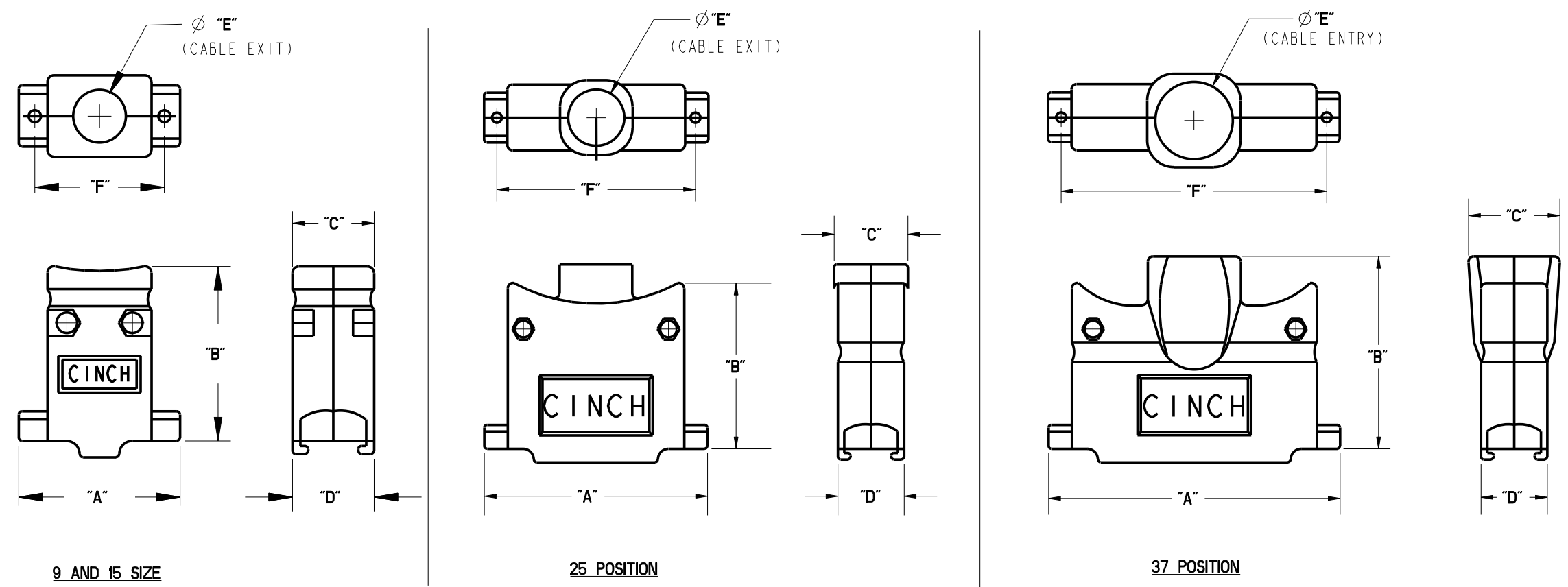

NOTES:

1. SPECIFICATIONS:

A. COVER - DIECAST ZINC

B. INSERTS - PLASTIC, PVC (BLACK)

C. HARDWARE
 SCREWS # 4-40
 HEX NUTS # 4-40
 SCREW MOUNTING BRACKET, STEEL,
 ZINC PLATE WITH CLEAR CHROMATE ROHS COMPLIANT.

2. DIMENSIONS IN [] ARE IN MILLIMETERS.

SIZE	CATALOG PART NUMBER	FACTORY NUMBER	"A"	"B"	"C"	"D"	"E"	"F"
9	DMH-E-003	702 49 09 022	1.225 [31.12]	1.465 [37.21]	.620 [15.75]	.620 [15.75]	.400 [10.16]	.984 [24.99]
15	DMH-A-003	702 49 15 022	1.540 [39.12]	1.600 [40.64]				1.312 [33.32]
25	DMH-B-003	702 49 25 022	2.090 [53.09]	1.570 [39.88]	.690 [17.53]		.525 [13.34]	1.857 [47.17]
37	DMH-C-003	702 49 37 022	2.730 [69.34]	1.810 [45.97]	.862 [21.89]		.725 [18.41]	2.500 [63.50]

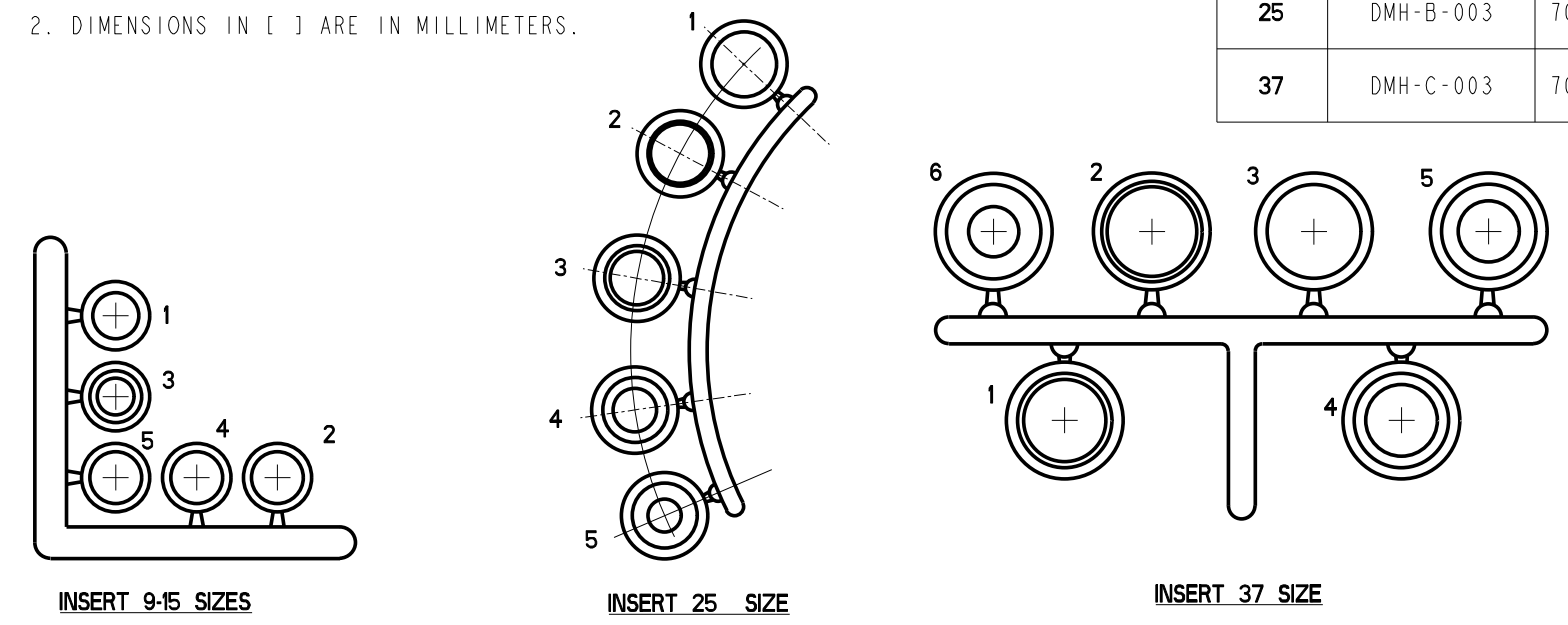

ROHS COMPLIANT

UNITS	ENGLISH	PRO/E	MODELED BY:
DO NOT SCALE DRAWING	DRAWN BY V. SKUZA	DATE 07/19/05	TITLE DIECAST HOOD D-SUB BACKSHELLS-2 PIECE
	DESIGN ENGINEER A. BALI	07/19/05	MATERIAL CONTROL SPEC NUMBER
	DESIGN ENGINEERING MGR. A. SHAH	07/27/05	MATERIAL SPEC NUMBER FINISH PROJECT NUMBER C14766
	MFG. ENGINEERING J. OCEGUERA	07/27/05	CAD FILE NUMBER DRAWING NUMBER DMH-X-003
	QUALITY ASSURANCE A. VAZQUEZ	07/27/05	CAGE IDENT NO. SIZE SCALE 71785 B 1:1 SHEET 1 OF 1

1700 FINLEY RD
 LOMBARD, IL. 60148