

REAR VIEW

2.6 REF [0.10]
SECONDARY LOCK SHIPPED
IN PRE-STAGED POSITION

INSULATOR COLOR: BLACK
(POLYAMIDE BASED
ALLOY GLASS-FILLED)

DATE CODE

BACK PLATE
COLOR: BLACK
(GLASS-FILLED POLYESTER)

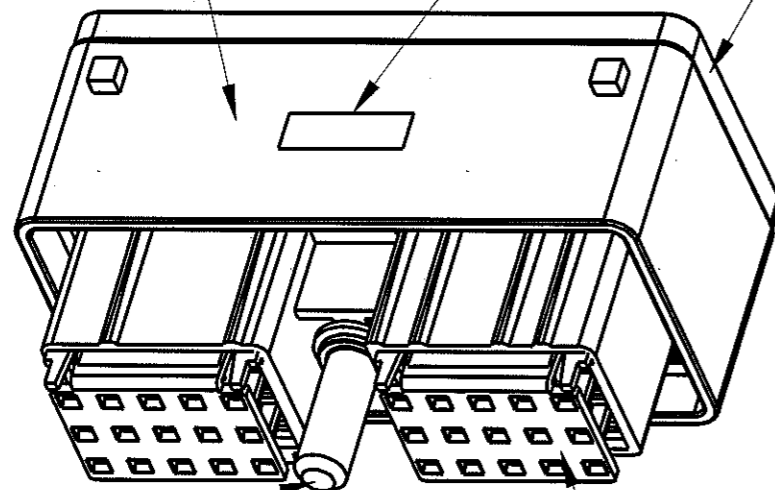

JACKSCREW, STEEL
10-24 UNC THREAD
(YELLOW CHROMATE)

SECONDARY LOCK
COLOR: WHITE
(GLASS-FILLED POLYESTER)

NOTES:

1. ALL DIMENSIONS ARE IN MILLIMETERS, DIMENSIONS IN [] ARE IN INCHES.
2. FOR WIRE SIZE APPLICATION, CONSULT FACTORY.
3. FEMALE TERMINAL ORDERED SEPARATELY: 425 00 00 873/872.
4. MATES WITH CINCH HEADER CONNECTOR (CONSULT FACTORY).
5. SEAL PLUG ORDERED SEPARATELY: 581 00 00 011.
6. STANDARD CELL PACK: QUANTITY 70 PIECES.
7. TOLERANCES UNLESS OTHERWISE SPECIFIED:
 .X ±0.5
 .XX ±0.25
8. SEALING RANGE FOR WIRE INSULATION DIA.;
 MAX 2.64MM (.104"), MIN 1.96MM (.077").
9. A TRIANGLE ▲ INDICATES CRITICAL FUNCTION DIMENSION.
10. IF TIE-WRAP DRESSING CONDUCTORS, CINCH RECOMMENDS A SPACING OF NO LESS THAN 2 INCHES BEHIND THE BACK PLATE.

DRAWING REVISIONS

REV	DOCUMENT	APP	DATE
A	RELEASE TO PRODUCTION PER D.O. 99-1161	AC	5/03/01
B	REMOVED 23.4 DIM. ADDED 2.6 REF DIM. ADDED SECONDARY LOCK NOTE. ADDED NOTE 9. ADDED CRITICAL SYMBOL TO DIMENSION 32.3 ADDED DATE CODE NOTE. PER ECN #01A583.	JLD	10/20/01
C	ADD: NOTE 10 ADD: TOL BLOCK COVER PER ECN #04A272.	AC	07/07/04
D	ECN 06A536 NOTE 10 WAS 4" BEHIND	JLD	11/20/06

MODELED BY:
J. DRYE

METRIC		PRO/E		Cinch	
DO NOT SCALE DRAWING		DRAWN BY B. KOSTIC	DATE 05/10/00	TITLE CONNECTOR ASSEMBLY SOCKET 30 POSITION	
		DESIGN ENGINEER A. CAINES	05/03/01	MATERIAL CONTROL SPEC NUMBER	
		DESIGN ENGINEERING MGR. J. DRYE	05/03/01	MATERIAL SPEC NUMBER FINISH PROJECT NUMBER A14243	
		MFG. ENGINEERING P. WALTHALL	05/03/01	CAD FILE NUMBER 5810130029S	DRAWING NUMBER 581 01 30 029S
THIS DOCUMENT IS THE PROPERTY OF CINCH. NEITHER THIS DOCUMENT NOR ANY OF THE INFORMATION CONTAINED IN IT MAY BE DUPLICATED OR DISCLOSED WITHOUT PRIOR WRITTEN CONSENT OF CINCH.		QUALITY ASSURANCE T. SHAH	05/03/01	CAGE IDENT NO. SIZE 71785 B	SCALE SHEET OF 1.500:1 1 OF 1

1700 FINLEY RD
LOMBARD, IL. 60148