

| DATE | REV | ECN | APP'D. BY |
|---------|-----|-------|-----------|
| 3-8-16 | A6 | 10595 | TRM |
| 9-29-16 | A7 | 10769 | TRM |
| | | | |
| | | | |

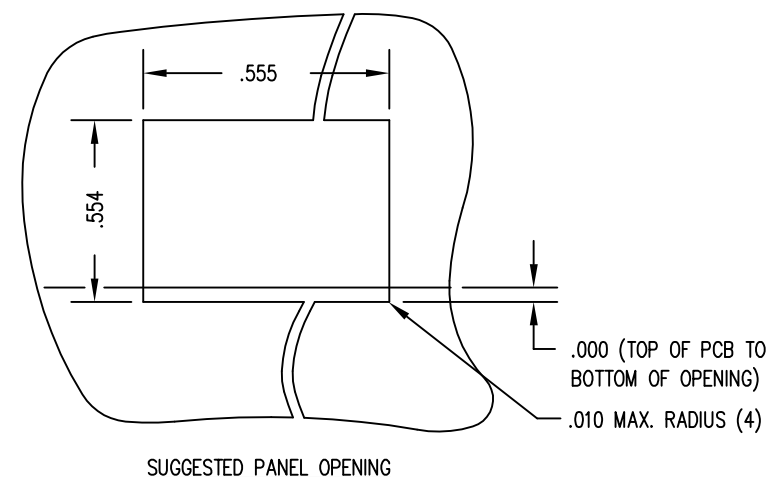

NOTES:

- CONNECTOR MATERIALS:
HOUSING: THERMOPLASTIC UL94 V-0
CONTACTS/SHIELD: COPPER ALLOY
SHIELD PLATING: NICKEL OR TIN
CONTACT PLATING: SELECTIVE GOLD IN CONTACT AREA
SEE CHART FOR PART NUMBER
- FOR PRODUCT SPECIFICATIONS SEE PR022-01.
- DIMENSIONS AND TOLERANCES COMPLY WITH TIA-1096 STANDARD.
- THE SUGGESTED PANEL OPENING IS INTENDED TO GIVE USER THE ABILITY TO HAVE REASONABLE JACK/PANEL CLEARANCES, YET MAINTAIN GROUNDING CAPABILITY. THESE VARIABLES CAN BE ADJUSTED IN EITHER DIRECTION BUT MAY CARRY SOME CONSEQUENCES IN THE FORM OF LOWER MATING FORCES OR TIGHTER ASSEMBLY TOLERANCES.

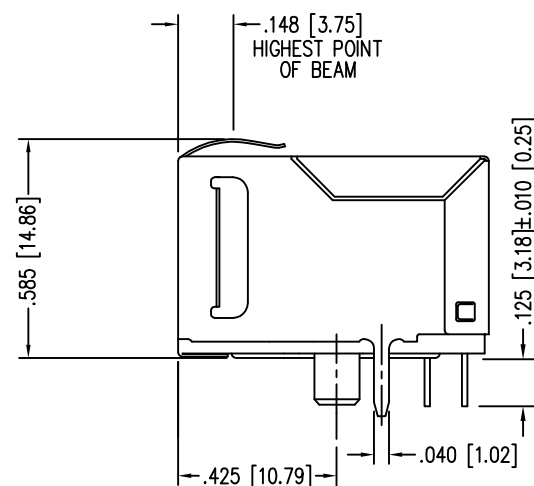
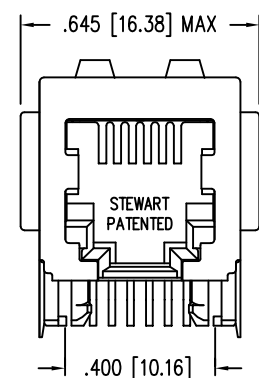
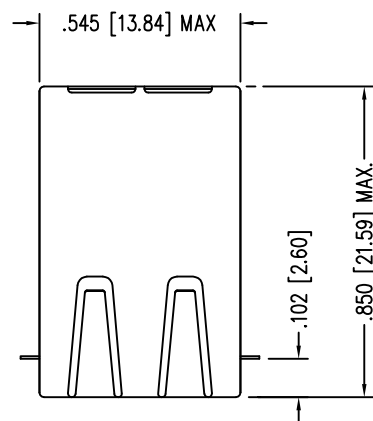
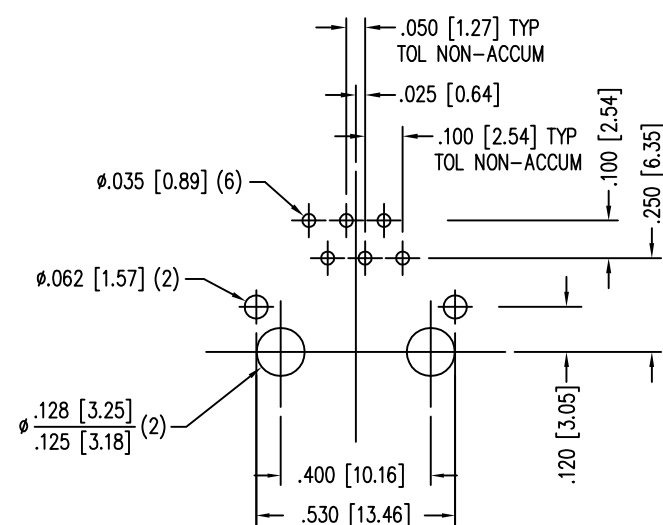

P.C.B. RECOMMENDED HOLE LAYOUT
SEEN FROM COMPONENT SIDE
TOLERANCE ±.003 [0.08] UNLESS OTHERWISE SPECIFIED

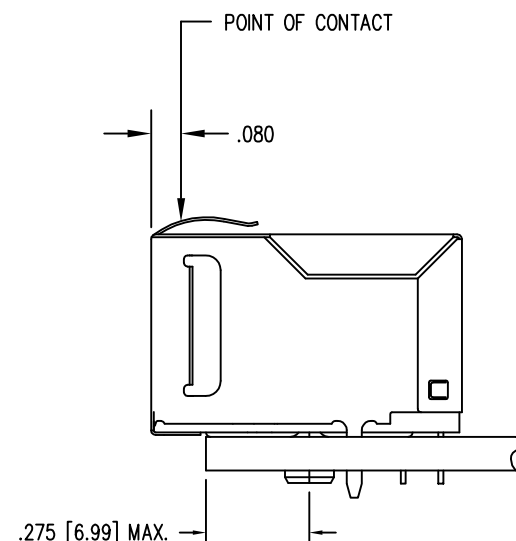

| | |
|-----------------------------------|---------------------|
| 30 MICRO-INCHES [0.76um] | SS-6466S-A-PGFLS-BB |
| CONTACT PLATING IN MATING AREA | PART NUMBER |

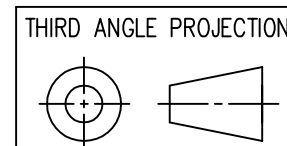

1118 Susquehanna Trail South
Glen Rock, PA 17327-9199
(717) 235-7512
<http://www.stewartconnector.com>

DO NOT SCALE DRAWING
DRAWING IS SUBJECT TO
CHANGE WITHOUT NOTICE

TITLE: SIX CONDUCTOR / SIX POSITION SHIELDED JACK,
FLANGED, TOP PANEL GROUNDS

DIMENSIONS: INCHES [METRIC]
UNLESS OTHERWISE SPECIFIED
TOLERANCES ARE ±.005 [0.13]
ANGLES ARE ± 1°

THIS DRAWING AND THE SUBJECT MATTER SHOWN THEREON
ARE CONFIDENTIAL AND THE PROPRIETARY PROPERTY OF
STEWART CONNECTOR AND SHALL NOT BE REPRODUCED,
COPIED, OR USED IN ANY MANNER WITHOUT PRIOR WRITTEN
CONSENT OF STEWART CONNECTOR. ONE OR MORE U.S. PATENTS
MAY APPLY TO THIS PRODUCT. FOR DETAILS, PLEASE
VISIT: [HTTP://BELFUSE.COM/STEWART/STEWART_PATENTS/](http://BELFUSE.COM/STEWART/STEWART_PATENTS/)

| | | | |
|----------|----------|------|---------|
| DRN BY: | KRL | DATE | 1/30/06 |
| APPD BY: | JM | DATE | 1-30-06 |
| DWG NO. | CT640178 | REV. | A7 |

SHEET NO. 1 OF 1