

DATE	REV	ECN	APP'D. BY
1-13-15	B7	10188	TRM
3-8-16	B8	10594	TRM
11-2-21	B9	11885	JE
7-10-23	C0	12210	JE

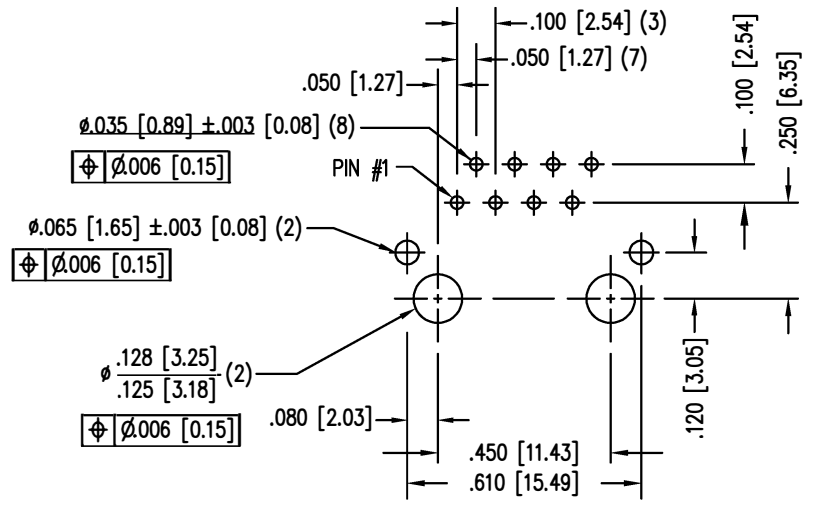
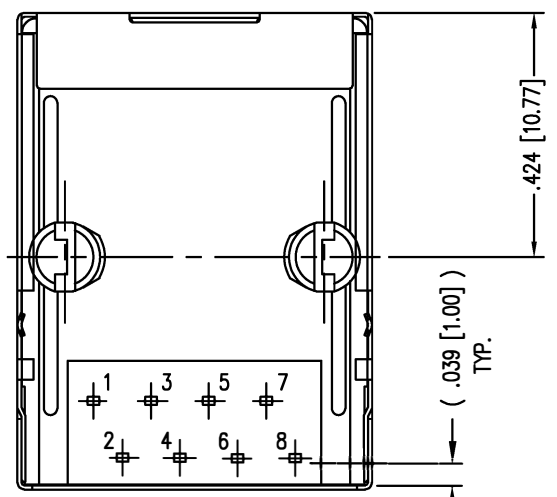
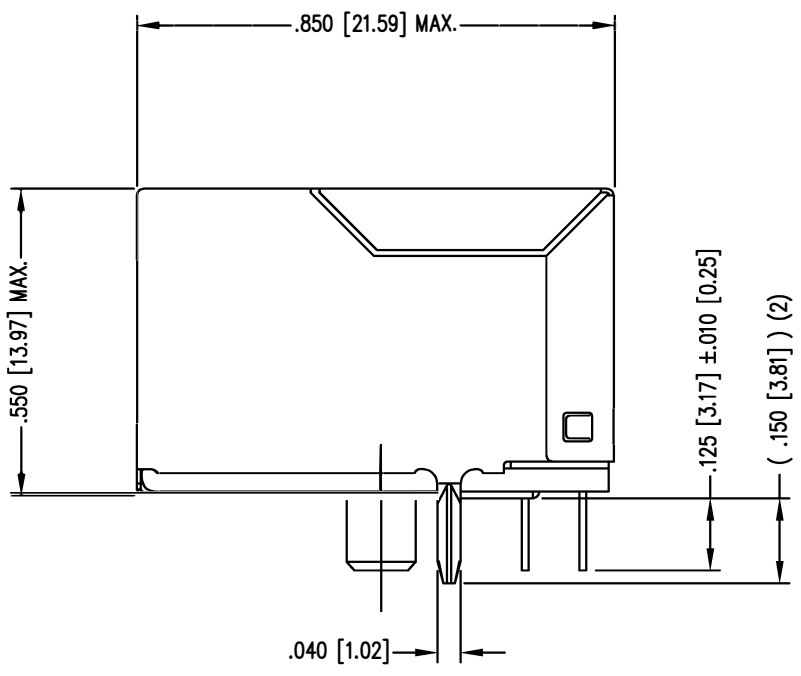
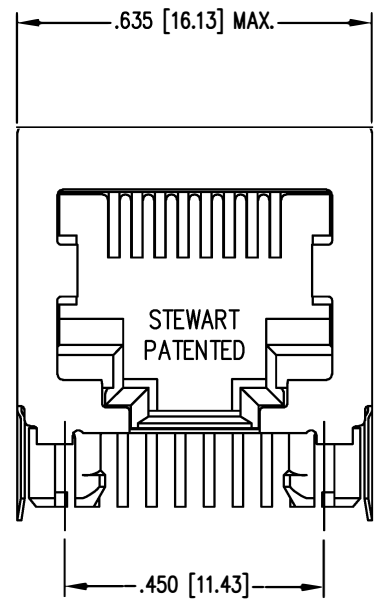

P.C.B. RECOMMENDED HOLE LAYOUT
SEEN FROM COMPONENT SIDE
ALL CENTERLINE DIMENSIONS ARE BASIC.

- NOTES:
- CONNECTOR MATERIALS:
HOUSING: THERMOPLASTIC UL94 V-0
CONTACTS/SHIELD: COPPER ALLOY
SHIELD PLATING: NICKEL OR TIN
CONTACT PLATING: SELECTIVE GOLD IN CONTACT AREA
SEE CHART FOR PART NUMBER
 - FOR PRODUCT SPECIFICATIONS SEE PR022-01.
 - DIMENSIONS AND TOLERANCES COMPLY WITH TIA-1096 STANDARD.

50 MICRO-INCHES [1.27um]	SS-6488S-A-NF-50
30 MICRO-INCHES [0.76um]	SS-6488S-A-NF
CONTACT PLATING IN MATING AREA	PART NUMBER

B

B

A

A

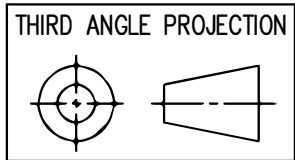

1118 Susquehanna Trail South
Glen Rock, PA 17327-9199
(717) 235-7512
<http://www.stewartconnector.com>

DO NOT SCALE DRAWING
DRAWING IS SUBJECT TO
CHANGE WITHOUT NOTICE

DIMENSIONS: INCHES [METRIC]

UNLESS OTHERWISE SPECIFIED
TOLERANCES ARE ±.005 [0.13]
ANGLES ARE ± 1°

SHEET NO. 1 OF 1

TITLE: EIGHT CONTACT, EIGHT POSITION, SHIELDED JACK
"-NF" NON-FLANGE

THIS DRAWING AND THE SUBJECT MATTER SHOWN THEREON ARE CONFIDENTIAL AND THE PROPRIETARY PROPERTY OF STEWART CONNECTOR AND SHALL NOT BE REPRODUCED, COPIED, OR USED IN ANY MANNER WITHOUT PRIOR WRITTEN CONSENT OF STEWART CONNECTOR. ONE OR MORE U.S. PATENTS MAY APPLY TO THIS PRODUCT. FOR DETAILS, PLEASE VISIT: [HTTP://BELFUSE.COM/STEWART/STEWART_PATENTS/](http://BELFUSE.COM/STEWART/STEWART_PATENTS/)

DRN BY: SAK	DATE: 5-13-94
APPD BY: JW	DATE: 9-23-94
DWG NO. CT640092	REV. C0

