

5

4

3

2

1

DRAWING NO. 27-8130-CUST											
REVISIONS											
OFFICAL RELEASE											
01	<table border="1"> <tr> <td>08-25-09</td> <td>T</td> <td>B</td> <td>T</td> <td></td> <td></td> <td></td> <td></td> <td><i>Betty</i></td> <td>2009.09.08 08.40.14 + 08.00</td> </tr> </table>	08-25-09	T	B	T					<i>Betty</i>	2009.09.08 08.40.14 + 08.00
08-25-09	T	B	T					<i>Betty</i>	2009.09.08 08.40.14 + 08.00		



Description: Adapter BNC Plug to Plug

Part No: 27-8130

Application: Adapter

Crimp Tool: N/A

Impedance: 50 Ohms

Fequency Range: 0-4 GHz

Material:

Body	Brass	Nickel Plated
Contact	Brass	Gold Plated
Insulator	Derlin	
Crimp Sleeve	Brass	Nickel Plated
Coupling Nut	Zinc	Nickel Plated

RoHS Compliance: Yes

Technical Detail: Refer to Emerson Document P/N 27-0000

受控 CONTROLLED DOCUMENT					
编号 P/N	27-8120-CUST	版本 Rev	01	日期 Rel'd Date	SEP 14,09

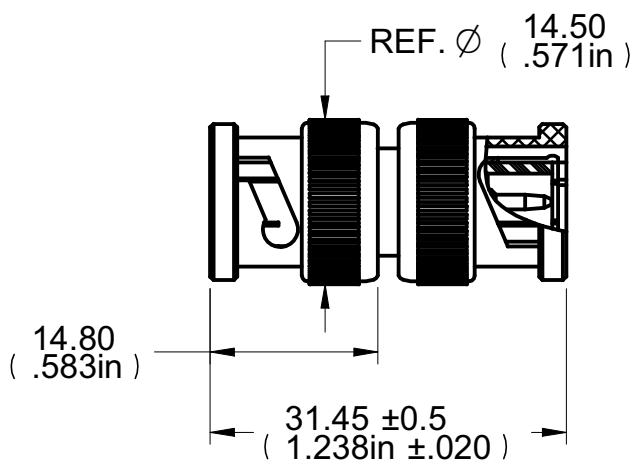

DIM OUTLINE

CUSTOMER COPY

TOLERANCE UNLESS OTHERWISE SPECIFIED		DRAWN BY TERRY.W		DATE 08-25-09		Connectivity Solutions	
DECIMALS	mm	CHECKED BY TERRY.W		DATE 08-25-09			
X	± 0.5	APPROVED BY THOMAS		DATE 08-25-09		TITLE ADAPTER BNC PLUG TO PLUG	
X.X	± 0.3	U/M		mm		SHEET 1 OF 1	
X.XX	± 0.1	THIS DRAWING WAS PRODUCED BY COMPUTER, DO NOT SCALE DRAWING OR UPDATE MANUALLY.		DRAWING NO. 27-8130-CUST		SIZE A	
ANGLES	± 0.5°						