

RoHS COMPLIANT

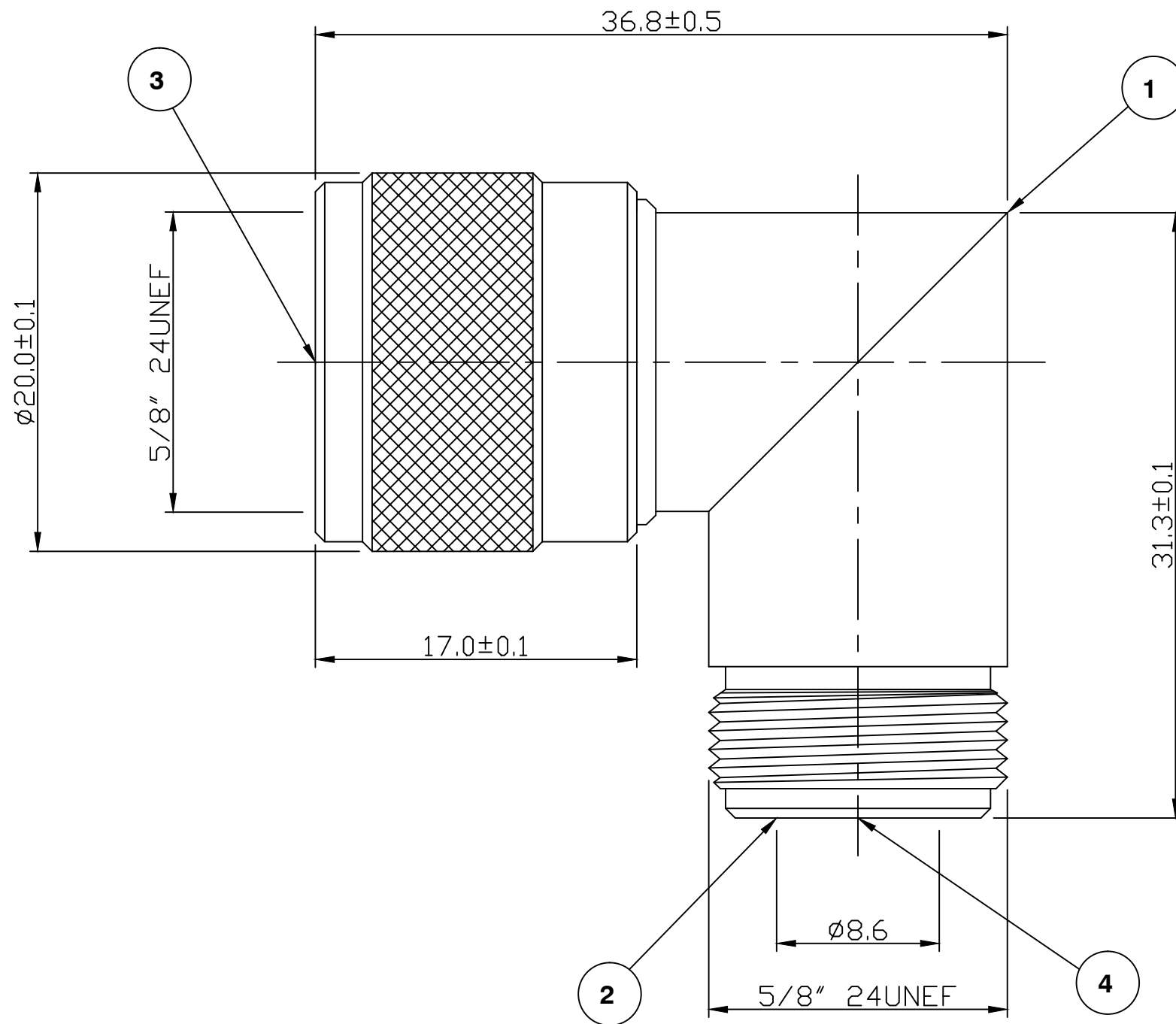

Nominal Impedance: 50 ohms
 Frequency Range: DC to 11 GHz
 Operating Voltage (rms): 1500 V maximum at sea level
 Dielectric Withstand Voltage (rms): 2500 V maximum at sea level
 Contact Resistance: 1.0 milliohms maximum
 Insulation Resistance: 5000 megohms minimum

Mechanical Characteristics

Mating Cycles: 500 cycles minimum
 Interface Dimensions: Conform to MIL-C-39012

Environmental Characteristics

Temperature Range: -55 °C to +85 °C

	PART	DESCRIPTION
1	Body	Brass, nickel plated
2	Dielectric	POM
3	Dielectric	PTFE
4	Contact	Brass, gold plated

Dimension Update - ECN D17505	MS	3	15 Oct 21
CAD Issue	SN	2	03 Oct 02
CAD Issue	SN	2	03 Oct 02
First Issue	IS	1	04 June 92
DESCRIPTION OF REVISION	APPVD	ISS	DATE



CINCH CONNECTIVITY SOLUTIONS
 11 Bilton Road,
 Chelmsford, Essex,
 CM1 2UP, UK.
 Tel: +44 (0) 1245 359515
 Fax: +44 (0) 1245 358938

SCALE: Not To Scale
 DIMENSIONS: mm
 TOLERANCES:
 ± 0.2mm unless
 otherwise stated

DRAWN BY: S Nash
 CHECKED BY: P Couzens
 APPROVED BY: P Couzens
 DATE: 03 Oct 02

TITLE:
Right Angle N Plug to N Jack

PART NUMBER:
VNA517

PAGE: 1 of 1