

PART NUMBER	ITEM ① MAIN BODY	ITEM ② MOUNTING BODY	ITEM ③ CONTACT	ITEM ④ INSULATOR	ITEM ⑤ BOLT X 2	ITEM ⑥ WASHER X 2
145-0701-802	STAINLESS STEEL PASSIVATED	BRASS NICKEL PL.00007 MIN OVER COPPER STRIKE	BERYLLIUM COPPER GOLD PL. .00004 MIN(MATING END) /.00003 MIN(SOLDER END) OVER NICKEL PL.00005 MIN OVER COPPER PL.00005 MIN	ULTEM 1000 (MATING END) /TEFLON (SOLDER END)	STAINLESS STEEL	STAINLESS STEEL

REV	ECO	DATE
1	ECO-17-0010	4/10/2017

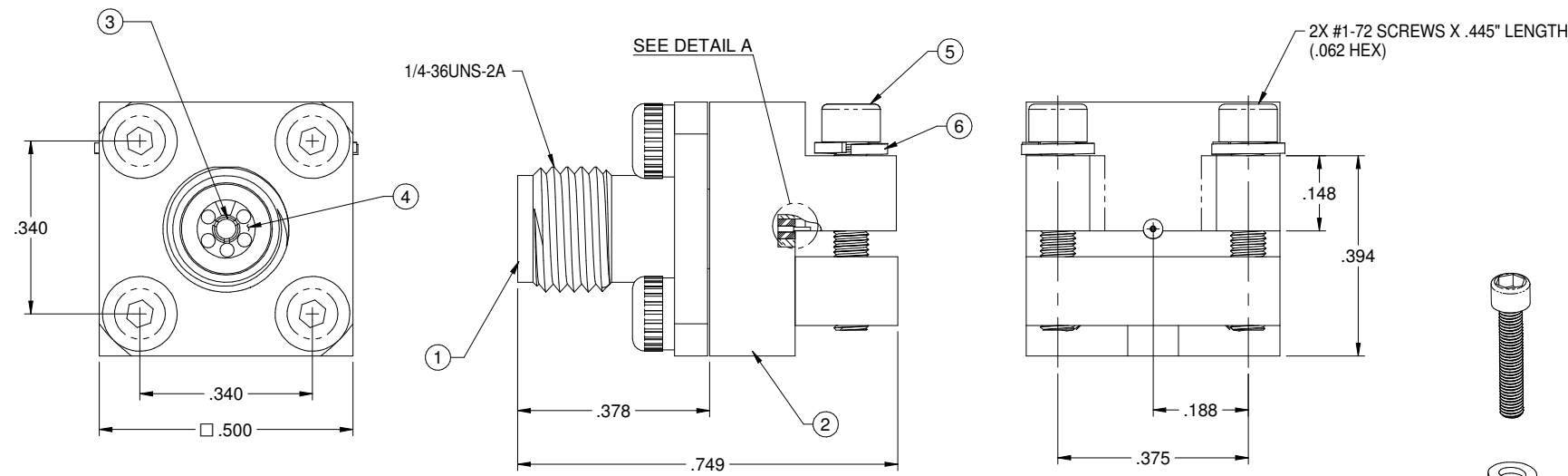
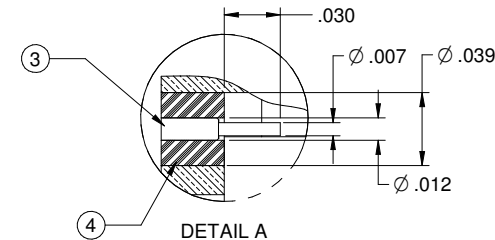

SPECIFICATION:

ELECTRICAL:
 IMPEDANCE: 50 OHMS
 FREQUENCY RANGE: 0-40 GHz
 VSWR: DEPENDANT ON APPLICATION
 WORKING VOLTAGE: 250 VRMS MAX AT SEA LEVEL
 DIELECTRIC WITHSTANDING VOLTAGE: 750 VRMS MIN AT SEA LEVEL
 INSULATION RESISTANCE: 5000 MEGOHM MIN
CONTACT RESISTANCE:
 CENTER CONTACT - INITIAL 3 MILLIOHM MAX, AFTER ENVIRONMENTAL NOT APPLICABLE
 OUTER CONDUCTOR - INITIAL 2 MILLIOHM MAX, AFTER ENVIRONMENTAL NOT APPLICABLE
 RF LEAKAGE: -90dB TYPICAL AT 2.5GHz

MECHANICAL:
 ENGAGEMENT/DISENGAGEMENT FORCE: 2 INCH-POUNDS MAX
 CONTACT RETENTION: 6 LBS MIN AXIAL FORCE
 MATING TORQUE: 7 TO 10 INCH-POUNDS
 DURABILITY: 500 CYCLES MIN

ENVIRONMENTAL:
 OPERATING TEMPERATUR: -40 TO 85°C
 THERMAL SHOCK: MIL-STD-202, METHOD 107, CONDITION B
 CORROSION: MIL-STD-202, METHOD 101, CONDITION B
 SHOCK: MIL-STD-202, METHOD 213, CONDITION I
 VIBRATION: MIL-STD-202, METHOD 204, CONDITION D

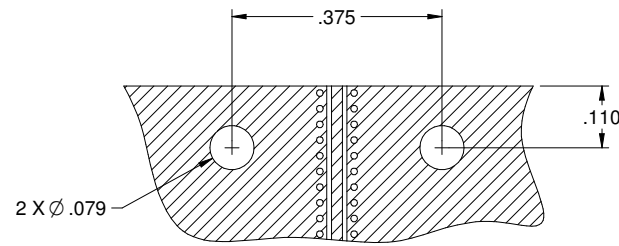

RECOMMENDED PCB LAYOUT
 NOTE: THIS PATTERN IS FOR REFERENCE ONLY.
 PATTERN MAY VARY DEPENDING ON BOARD TYPE, SPECIFIC ELECTRICAL OR MECHANICAL REQUIREMENTS.

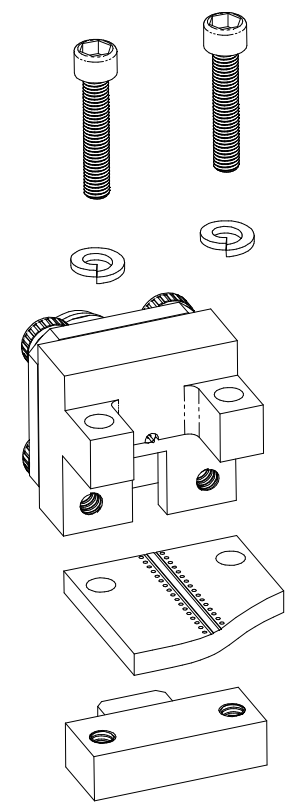

	Revision: SEE NOTE Model No.: RoHS2 201185 EU Date: 2017-04-10	Title: END LAUNCH JACK SCREW-ON TYPE SMK(2.92mm)
--	--	---